

Can-Am HD11 - Dual Idler 15% - PGL-415DI-HD11 Can-Am HD11 - Dual Idler 30% - PGL-430DI-HD11

Cam Am Defender HD 11 4" Dual Idler Portal Kit



HIGHLIFTER

SEIZMIK™



✉ sales@highlifter.com
☎ 800-699-0947 | 8:00am - 5:00pm CST
📍 7455 Atkinson Drive, Shreveport, LA 71129



www.highlifter.com

Parts Available For These Popular Brands and Others

POLARIS

can-am



HONDA

Kawasaki

YAMAHA

PRODUCT DISCLAIMER:

The installation of products sold or manufactured by High Lifter Products including, but not limited to suspension components such as lift kits, gear reduction lifts, frame stiffener kits, snorkels, and tires that exceed the original specifications for the vehicle, may change the vehicle's center of gravity and handling characteristics both on- and off-road. You are aware that the installation of tires that are larger than original vehicle specifications may reduce the effectiveness of the braking system. Use of these products may place added stress to the original factory vehicle components which could cause them to weaken or possibly fail.

Products sold or manufactured by High Lifter Products are intended for off-road use only. Operation of a vehicle modified with these products on a road could result in serious bodily injury or death, and such operation may violate the laws of your state or municipality. You agree to operate your vehicle exclusively in the manner intended by the vehicle manufacturer. You agree that failure to safely and reasonably operate your vehicle could result in serious bodily injury or death, and that, as a result of installation of this product(s) to your vehicle, extreme care must be taken to prevent vehicle rollover or loss of control, which may be more likely to occur as a result of said modifications. You will avoid unsafe maneuvers, including sudden sharp turns or other abrupt maneuvers, which could make a vehicular accident more likely. You understand that High Lifter Product is not responsible or liable for any damages or any injuries to yourself or your passengers that could occur upon possible accidents due to driver error, incorrect installations, bad judgment, incompatibility with other aftermarket accessories or natural disasters to the fullest extent allowable by law.

You will have all vehicle occupants fasten seatbelts, if equipped, and wear proper safety equipment, such as DOT approved helmet and eye protection prior to operating the vehicle. You understand and acknowledge that failure to wear proper safety equipment may increase the risk of serious bodily injury or death to yourself and any passengers.

Proper installation of products sold or manufactured by High Lifter Products requires knowledge of the factory recommended procedures for removal and installation of original equipment components. Installation of these products without proper knowledge and experience may affect the performance of these components and the safety of the vehicle and cause serious bodily injury or death. It is strongly recommended that a certified mechanic familiar with the installation of similar components perform the product(s) installation.

Prior to installing any products sold or manufactured by High Lifter Products, you will perform or cause to be performed an inspection of their vehicle to confirm its condition is suitable for the installation of these products. A proper inspection of the vehicle includes confirmation that the vehicle has not been in a collision and is free of corrosion. If the vehicle is suspected to have been in a collision or misused, or is otherwise unsuitable for modification, you will not install the product(s). You will continue to inspect the vehicle prior to each use to confirm its condition is suitable for its intended use, and you acknowledge that the failure to do so may result in serious bodily injury or death, as well as damage to the vehicle itself.

You will install any warning labels provided with the product so it may be prominently seen by yourself and all passengers. You will notify all passengers of the modifications performed to your vehicle prior to operation.

Insurance companies may handle coverage of a modified vehicle differently. Please check with your insurance carrier prior to modifying the vehicle to ensure your coverage remains sufficient.

Installation of this product(s) may void your vehicle warranty. If this is a concern, please check with the manufacturer or dealer before purchase or installation of this product(s).

INTRODUCTION



READ THESE INSTRUCTIONS CAREFULLY. IT IS RECOMMENDED THAT A PROFESSIONAL MECHANIC PERFORM THE INSTALLATION. CARE SHOULD BE TAKEN TO FOLLOW ALL STANDARD SAFETY PROCEDURES.

PRIOR TO INSTALLATION, A THOROUGH INSPECTION OF THE SUSPENSION SHOULD BE MADE. INSPECT THE VEHICLES STEERING, DRIVELINE, AND BRAKE SYSTEMS, PAYING CLOSE ATTENTION TO THE SUSPENSION LINK ARMS AND BUSHINGS, ANTI-SWAY BARS AND D BUSHINGS, TIE ROD ENDS, BALL JOINTS AND WHEEL BEARINGS.

ALSO CHECK THE STEERING SECTOR-TO-FRAME AND ALL SUSPENSION-TO-FRAME ATTACHING POINTS FOR STRESS CRACKS. THE OVERALL VEHICLE MUST BE IN EXCELLENT WORKING CONDITION. ANY WORN, BENT OR BROKEN PARTS SHOULD BE REPAIRED AND/OR REPLACED.

NOTE: DO NOT ADD OR FABRICATE ANY COMPONENTS TO GAIN ADDITIONAL SUSPENSION HEIGHT.

NOTE: AFTER INSTALLATION, ANOTHER INSPECTION SHOULD TAKE PLACE, CHECKING FOR LOOSE COMPONENTS OR MISSING HARDWARE. INSPECT, AGAIN AFTER EIGHT (8) HOURS OF OPERATION. REMEMBER TO CHECK THE LUG NUTS AGAIN.

NOTE: A FACTORY SERVICE MANUAL SHOULD BE ON HAND FOR REFERENCE. THE MANUAL WILL CONTAIN FASTENER TORQUE SPECS, ASSEMBLY TECHNIQUES, AND SPECIAL TOOL REQUIREMENTS THAT ARE UNIQUE TO THIS PARTICULAR YEAR AND MODEL VEHICLE.

REQUIREMENTS



TOOLS

- Jack Stand
- Metric & standard socket assortments
- Metric & standard hex key/ sockets
- Torque wrench
- Multi-purpose pliers
- Wire cutter/snips
- Mallet (Soft face hammer)
- Drift punch/pin
- Vice or Press



TIRE REQUIREMENTS

- Up to 30" Stock
- 31" with 3" Lift Kit
- 32" to 33" Forward Kit 1.5"
- 34" Forward Kit and Lift Kit
- 35" to 37" Big Lift Kit (45%)
- 38" to 39" Big Lift Kit (45% or 60%)
- 40" to 44" Big Lift (STRONGLY SUGGEST 60%)



SUPPLIES

- Water-resistant grease
- DOT 4 brake fluid
- 80w90 gear oil











WHEEL REQUIREMENTS

- 18" or larger wheel required
- 18" wheels cannot exceed 4-1/2" backspacing
- 20" and larger wheels cannot exceed 5" backspacing

PARTS DIAGRAM

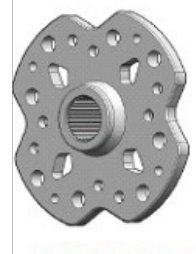



HARDWARE & BRAKE LINES (PGLBOX-C403-D1-B1)

 HC812434Z 1/2" x 4- 3/4" Bolt (4ea)	 PGLC-SOCKET46MM 46mm Socket (1ea)	 PGLC-AXNUT-5 M20 x 1.5 Shoulder Axle Nut(4ea)	 LOCTITE-02 Red Loctite (1ea)	 SK-VT-1 1/4 Clear Hose (3ft)
 HC812412Z 1/2" x 4- 1/2" Bolt (12ea)	 FW12SAE 1/2 Flat Washer (32ea)	 NLN8 1/2 Nylon Nut (Grade 8) (16ea)	 128P- PGLC-WSTUD-104 12mm x 1.5 TP Stud (16ea)	
 MCS10X30-10.9 M10x30mm Bolt (8ea)	 MFW10 1/2 Flat Washer (8ea)	 129Z Caliper Bracket (4ea)	 79-15281 Rear Brake Line 10.5" Extension (4ea)	
 MCS520 M5 x .80mm x 20mm Bolt (6ea)	 BSH381 3/8 x 1" Button Head Allen Bolt (16ea)		 T11RB 11" Zip Ties (2ea)	 LOCTITE-02-B Blue Loctite (1ea)
 MCS516 M5 x .80mm x 16mm Bolt (4ea)	 CP5322Z Cotter Pin (4ea)	79-84484 Bushing Kit (1ea)	HUB & ROTOR (PGLBOX-HRB-402A)	
 WL-CLAMP-12 1/2 Loom Camp (4ea)	 PGLC-ROTOR-SP 1/2 Rotor Spacer (16ea)	 47S Steering Stop (4ea)	 PGLC-HUB-203 33 Spline (4ea)	 PGLC-ROTOR-5 10" ROTOR (4ea)
 MFW5 5mm Flat Washer (10ea)	 MLN5-0.8 M5 x .80mm Lock Nut (10ea)	 T50RB 8" Zip Ties (14ea)		

FRONT BACKING PLATES (PGL-BOX-C403-DI-B2B1)

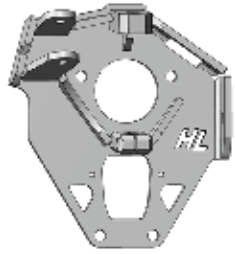
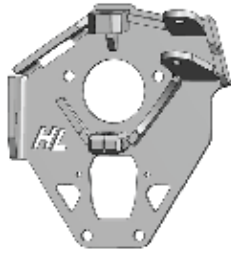
PORTALS

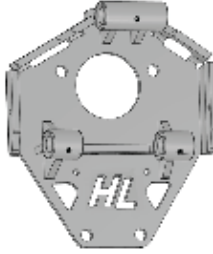
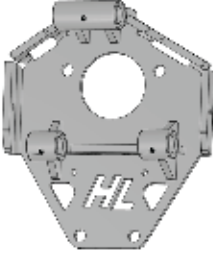
REAR BACKING PLATES (PGL-BOX-C403-DI-B3B1)

 79-84381-L-B1 Left Front Portal Backing Plate (1ea)	 79-84381-R-B1 Right Front Portal Backing Plate (1ea)	 Portal Assembly (4ea) FRONT PGLAB-430-DI-C401A (30%) PGLAB-415-DI-C401A (15%) REAR PGLAB-430-DI-C402A (30%) PGLAB-415-DI-C402A (15%)	 79-84380-L-B1 Left Rear Portal Backing Plate (1ea)	 79-84380-R-B1 Right Rear Portal Backing Plate (1ea)
			 GF-1428-90 Grease Fitting (6ea)	

FRONT INSTALL

FRONT WHEEL

REMOVAL

1



FRONT PASSENGER SIDE

KEEP ALL FACTORY HARDWARE.
Place jack under the FRONT center of the UTV and lift until the weight is off the suspension. Ensure that the vehicle is properly secured.

Raise unit an additional 4" to accommodate portals.

Remove the front wheels.

BRAKE CALIPER AND BRAKE LINES

REMOVAL

2

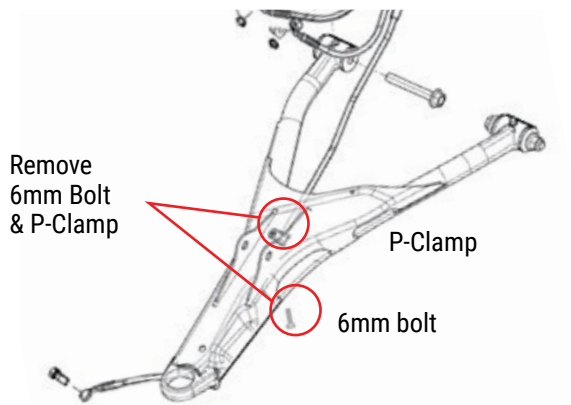

Disconnect brake lines by removing the 6mm bolt from the p-clamps from under the arm.

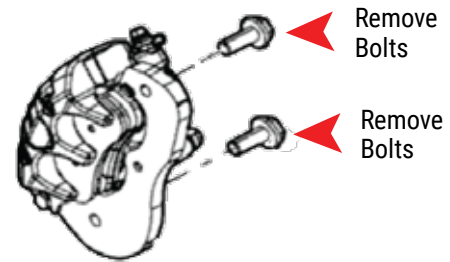

Remove the brake caliper mounting bolts (15mm)
Set caliper aside.

HUB ASSEMBLY

REMOVAL

3

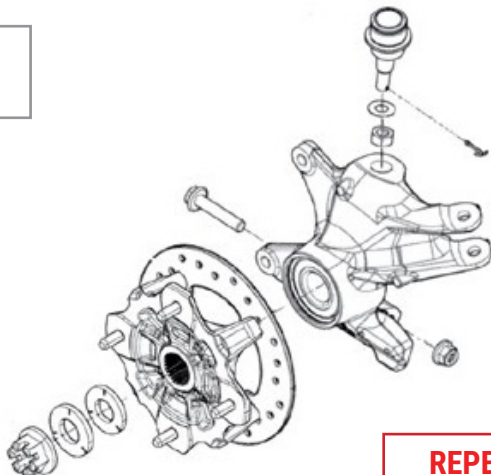

Remove the cotter pin, axle nut, and washers from the hub assembly, then remove the hub. (30mm)

REPEAT STEPS ON OPPOSITE SIDE

4

TIE ROD END



Disconnect the tie rod from the knuckle. (15mm)

KEEP ALL FACTORY HARDWARE.

UPPER BALL JOINT

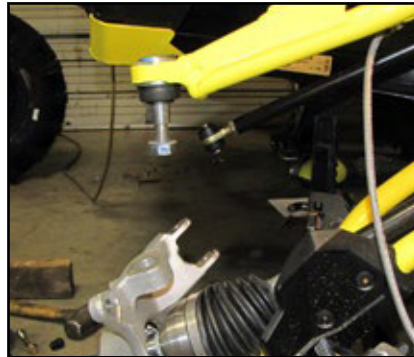

Disconnect the Upper ball joint by removing the cotter pin and bolt. (19mm)

LOWER BALL JOINT



Disconnect the Lower ball joint by removing the bolt at the knuckle. (15mm)

STEERING STOP



NOTICE: DO NOT remove the pinion. The images featured are for DEMONSTRATIVE PURPOSES ONLY.

5

BOOT REMOVAL

The rubber boots on the rack and pinion are held on by zip ties. You will need to cut the zip tie that secures the boots to the inside of the rack and pinion.

START WITH THE DRIVER'S SIDE

This side has the least amount of room. Once you install the spacer on the passenger side you will have less play on the driver's side. **DO NOT REMOVE THE FACTORY SPACER ALREADY IN PLACE.** Turn the steering wheel all the way to the **RIGHT**. Place (2) steering stops between the inner tie rod joint and the rack and pinion.

PASSENGER SIDE

Turn the steering all the way to the left. Place (2) steering stops between the inner tie rod joint and the rack and pinion. It is a tight fit, so you may have to force it on, this is to ensure that the spacer stays in place.

RE-SECURING BOOT

Turn the steering wheel closer to the center to allow play in the boot. Slide the boot back down and secure it with an 11" zip tie.



Install steering stops to the pinion shafts.

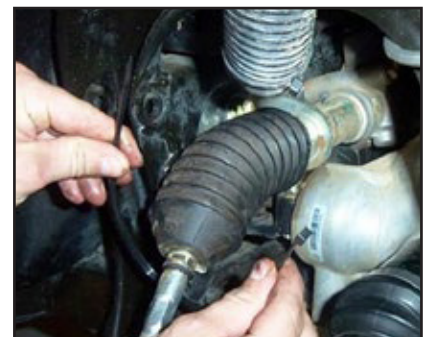
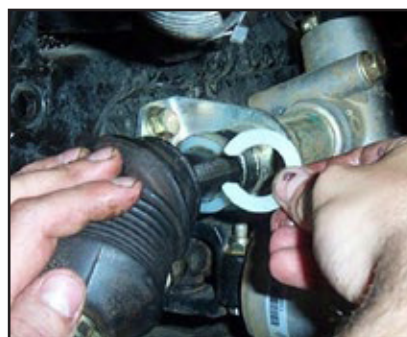

FRONT INSTALL

FRONT BACKING PLATE

INSTALL

6

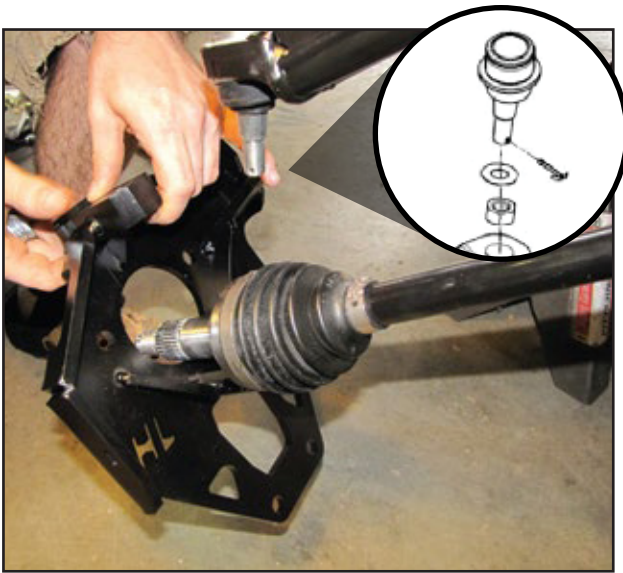

Place the backing plate into position on the control arms and guide the axle through.

Insert the upper ball joint into the upper mount bracket. Secure with factory nut, washers, and cotter pin.

Insert the lower ball joint into the lower mount bracket on the backing plate.

Fasten ball joints with the factory hardware (15mm)
Torque: 50 ft lbs

NOTE: You may need to clean powder coating from the hole.

BOX CAP

7

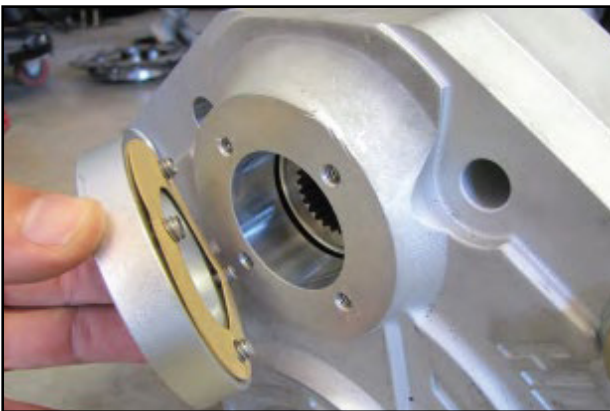

Remove the 1/4 - 20x3/4" screws, cap, and gasket from the lid of the assembled portal box

FRONT CALIPER BRACKET

INSTALL

8

REAR

Install the 129Z caliper bracket facing the REAR of the vehicle.

YOU MUST DISCARD THE PRE-INSTALLED LOCK WASHER.

The bolt head should sit flush with the bracket.

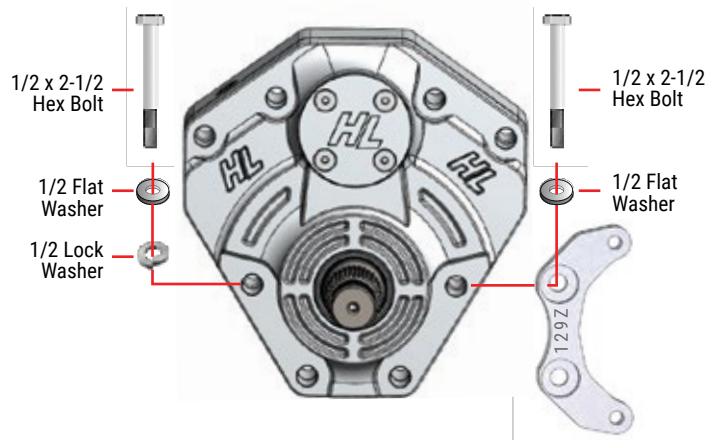

FRONT

Each side has preinstalled hardware on the portal box.

The installment should look like the featured diagram, when complete.

FRONT INSTALL

FRONT CALIPER BRACKET

INSTALL

9

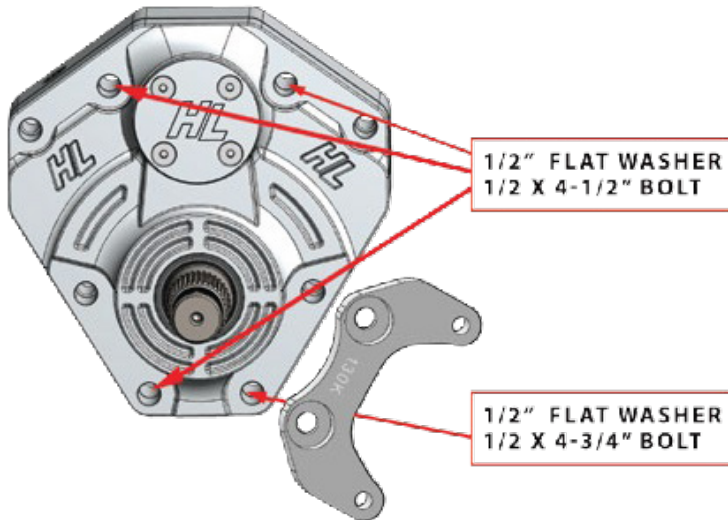

Insert the washers and bolts below through the remaining (4) holes in the front portal box.

FRONT PORTAL

INSTALL

10

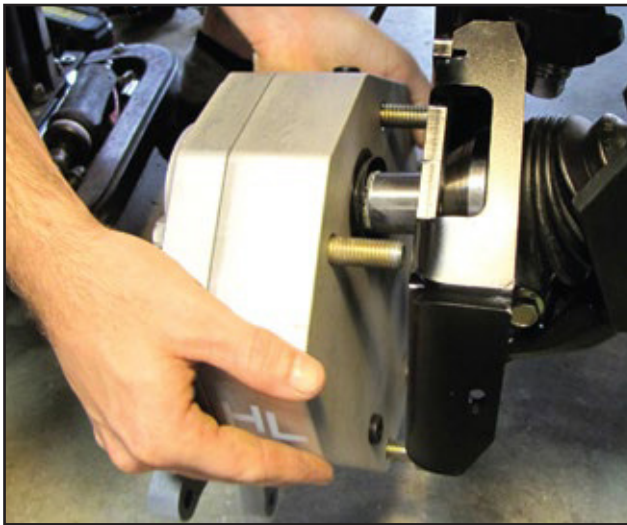

Apply water-resistant grease to the drive splines. Be sure to apply product all around the outer edge as well.

Rotate the portal box 'Up & In' as you guide the drive shaft axle through the inner drive gear.

Insert the bolts through the corresponding holes in the backing plate.

11

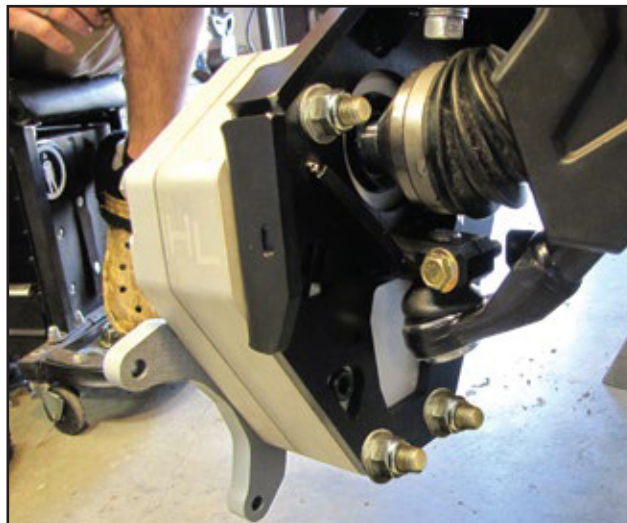

Loosely fasten all (4) bolts with 1/2" flat washers and 1/2" lock nuts. Ensure parts fit correctly then torque. (3/4) [105 ft lbs]

REPEAT STEPS ON OPPOSITE SIDE

FRONT INSTALL

TIE ROD

INSTALL

12



Install the tie rod end into the backing plate mount bracket. Fasten with the factory hardware. **(18mm) [90 ft lbs]**

NOTE: If you are using our High Lifter Big Lift or Front Forward Arms in conjunction with this portal kit, you may need to drill out the tie rod mount bracket to utilize the steering hardware you are currently using.

FRONT PORTAL

INSTALL

13



Apply LOCTITE (BLUE) to the supplied M20 shoulder axle nut (PGLC-AXNUT-5) and torque onto the drive shaft axle. **(30mm) [20 ft lbs]**

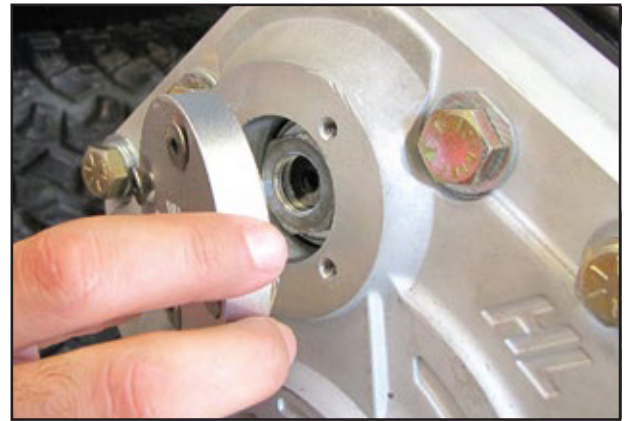

Align the portal box lid & gasket. Use the 1/4-20 x 3/4" screws and install the cap to the portal box. **[8 ft lbs]**

ROTOR ASSEMBLY

INSTALL

14

Locate all (4) multi pattern hubs, so they can all be assembled at the same time. They are designed to work with different bolt pattern.

NOTE: They may have oil on them to prevent corrosion. If so, you will need to use a cleaner and remove most of the oil.

With the shorter lip side faced down, find the bolt pattern that corresponds to your make and model. Use the provided studs (10mm-1.5 stud) (4/137mm bolt pattern)

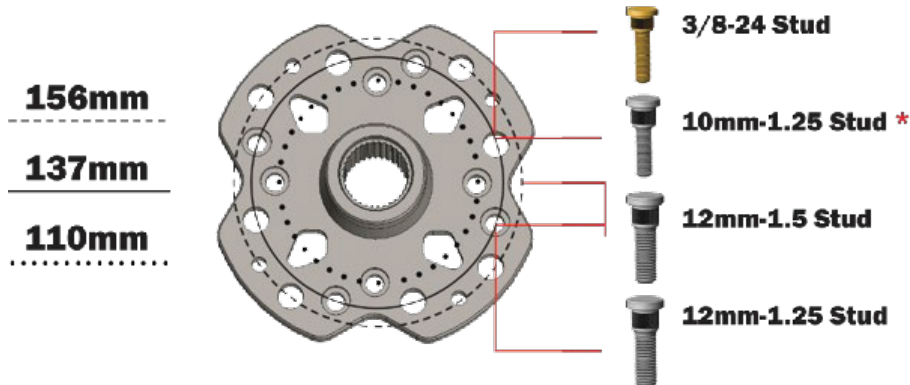

15

For the following steps, place this side (the shorter lip) face down on your working surface.

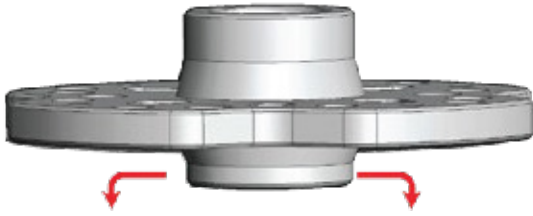

This side will face away from the UTV when installed.

17

Place the 1/2 spacers over the tapped holes. These spacers go BETWEEN the hub and rotor.

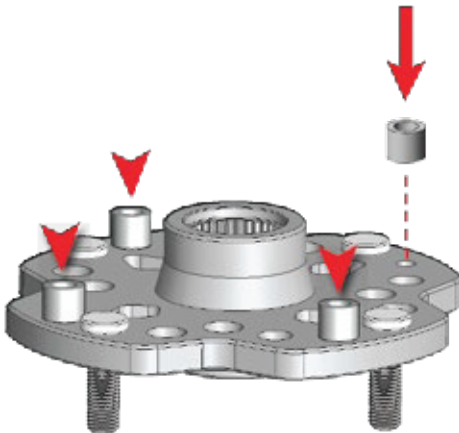

16

! DO NOT PRESS THE STUDS INTO THE TAPPED HOLES THAT ARE FOR THE ROTOR.

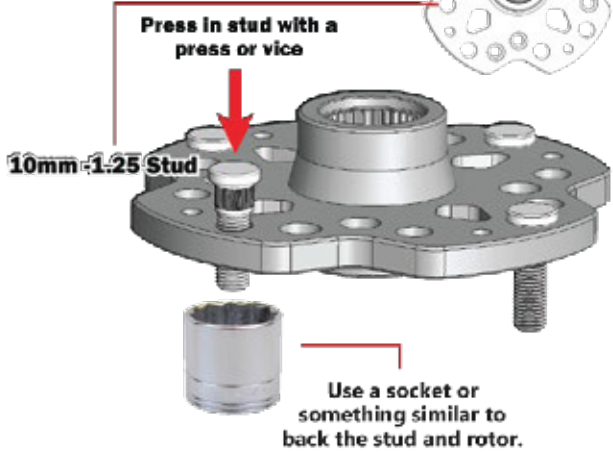

NOTE: COUNTER BORES ON ROTOR SHOULD BE FACING UP.

Install the rotor and secure it to the hub by applying **LOCTITE (RED)** to the (4) 3/8 x 1-1/4" hex head bolts & (4) 3/8 lock washer. (7/32) [45 ft lbs]

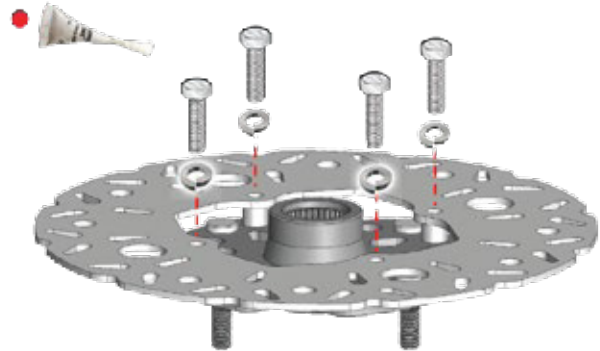

19



Apply waterproof grease to the spindle splines and slide the brake rotor onto the spindle shaft.

20

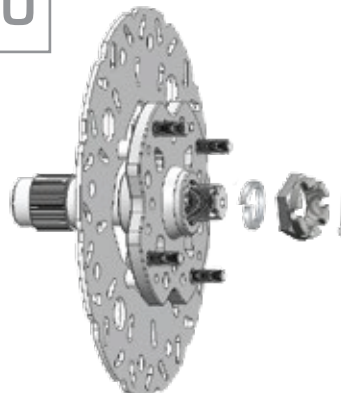

Slide on the 30mm lock washer, 30mm castle nut. (46mm) [Min 120 ft lbs]

Tighten the castle nut further if needed to align grooves with hole in the spindle for the cotter pin.

Install the cotter pin, then bend it to secure it.

21

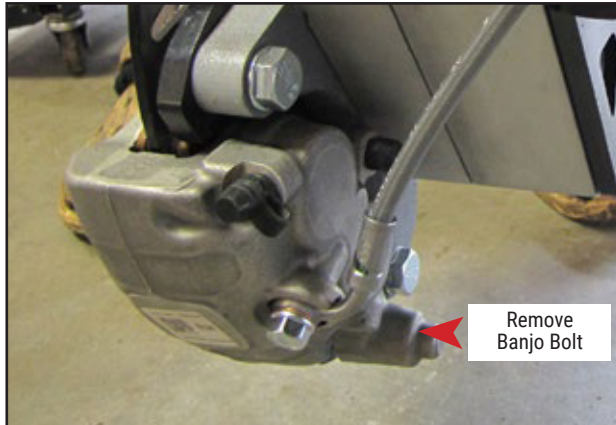

Disconnect the stock brake line from the caliper, if you have not done so already.

Have a container ready to collect fluid.

NOTE: IF YOU ARE HAVING DIFFICULTY REMOVING THE BOLT, MOUNT THE BRAKE CALIPER TO THE BRACKET, THEN LOOSEN THE BANJO BOLT.

REPEAT STEP ON OPPOSITE SIDE

22



Secure the brake line to the front of the portal backing plate by using a p-clamp. Insert a 5mm x 20mm bolt through the clamp and backingplate, followed by a 5mm washer and 5mm lock nut. Ensure there is no pinching or binding on the lines and that there is not contact with moving parts.

See Step 34 for Brake Line Extension Installation

REAR INSTALL

REAR WHEELS

REMOVAL

23



REAR PASSENGER SIDE

KEEP ALL FACTORY HARDWARE.

Place jack under the REAR center of the UTV and lift until the weight is off the suspension. Ensure that the vehicle is properly secured.

Raise unit an additional 4" to accommodate portals.

Remove the rear wheels.

CALIPER & HUB

REMOVAL

24

CALIPER

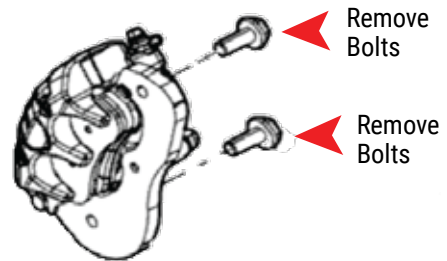

Remove the brake caliper mounting bolts from the hub assembly. (15mm) Set caliper aside.

25

HUB

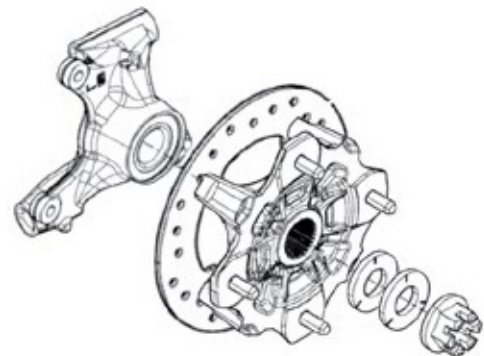

Remove the cotter pin and castle nut (30mm) on the rear axles, then remove the brake rotor assembly.

REPEAT STEPS ON OPPOSITE SIDE

26

REAR KNUCKLE ASSEMBLY

Remove the bolts (15mm) and nuts that attach the rear knuckle to the upper & lower A-arms.

Install the bushings and sleeves provided in kit.



Remove sleeves from both arms.

Use a screw driver to pry the bushings from the pivot collars.

NOTE: Use caution when removing the bushings from the knuckle. These are plastic bushings and can be damaged easily.

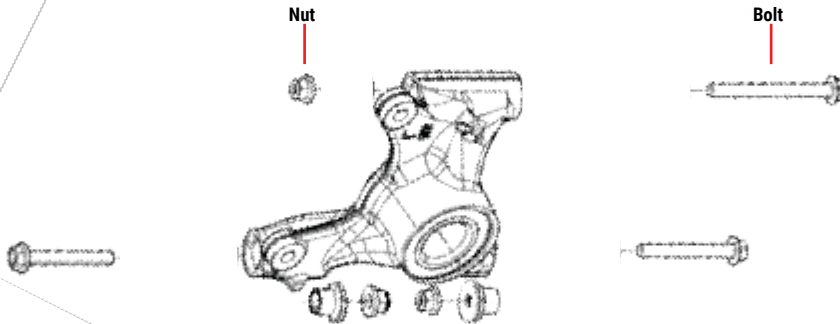

27

REAR BACKING PLATE

Insert the bushings and sleeves into the collars of the rear backing plate. Install the grease fittings. DO NOT OVER TIGHTEN.

NOTE: We recommend applying quality water-resistant grease to the bushings, especially inside the pivot collar and along the sleeve.



 **GF-1428-90**
Grease Fitting (6ea)

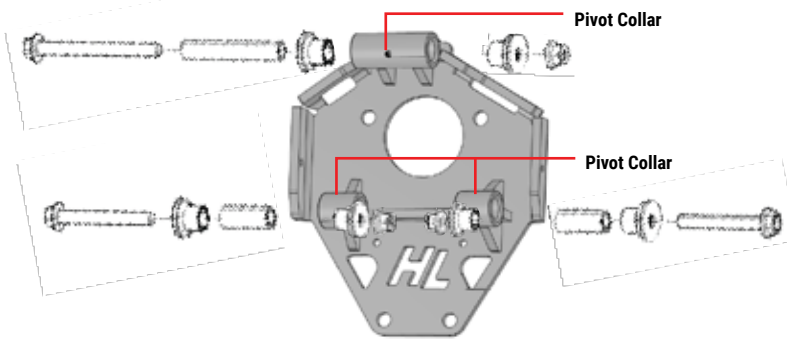

REPEAT STEPS ON OPPOSITE SIDE

REAR INSTALL

REAR BACKING PLATE

INSTALL

26

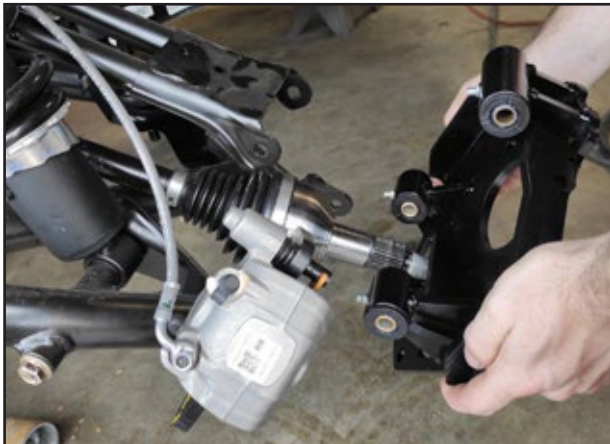

Place the backing plate into position on the control arms and guide the drive shaft through.

Use the factory hardware to fasten the plate to the lower control arm. (15mm) Torque [90 ft. lbs]

Fasten to the upper control arm. (15mm) Torque [50 ft. lbs]

BOX CAP

INSTALL

27

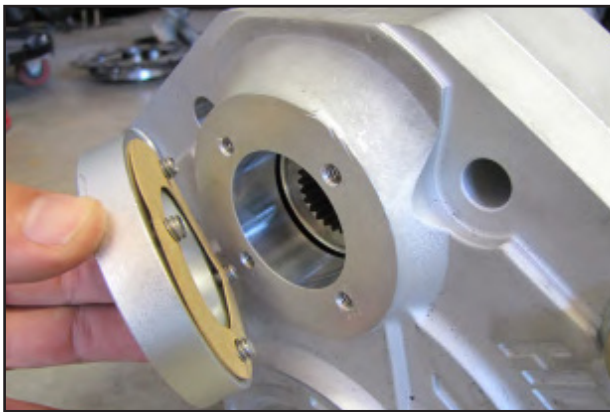

Remove the 1/4-20 x 3/4" screws, cap, and gasket from the lid of the assembled portal box.

REAR CALIPER BRACKET

INSTALL

28

REAR

Install the 129Z caliper bracket facing the REAR of the vehicle.

YOU MUST DISCARD THE PRE-INSTALLED LOCK WASHER.

The bolt head should sit flush with the bracket.

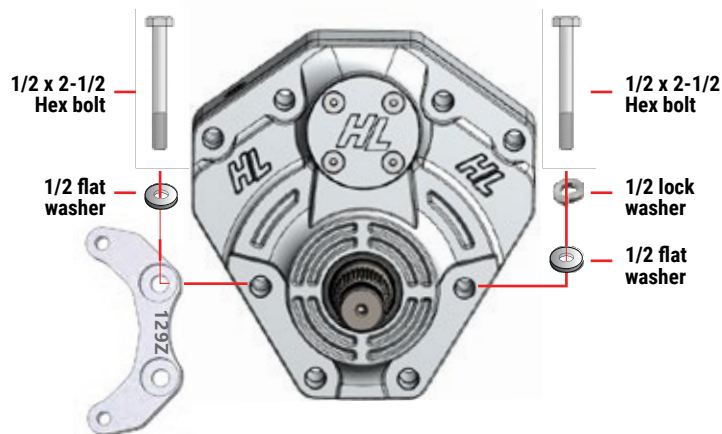

FRONT

Each side has preinstalled hardware on the portal box.

The installment should look like the featured diagram, when complete.

REPEAT STEPS ON OPPOSITE SIDE

29

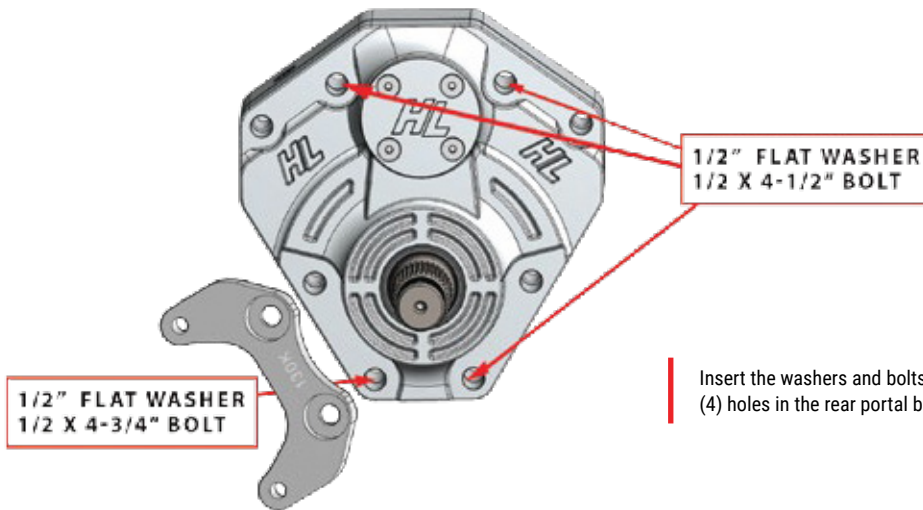

Insert the washers and bolts below through the remaining (4) holes in the rear portal box.

30



Apply water-resistant grease to the drive splines. Be sure to apply product all around the outer edge as well.

Rotate the portal box 'Up & In' as you guide the drive shaft axle through the inner drive gear.

Insert the bolts through the corresponding holes in the backing plate.

31



Loosely fasten all (4) bolts with 1/2" flat washers and 1/2" lock nuts. Ensure parts fit correctly then torque. **(3/4) [105 ft lbs]**

REPEAT STEPS ON OPPOSITE SIDE

REAR INSTALL

REAR AXLE NUT

INSTALL

32

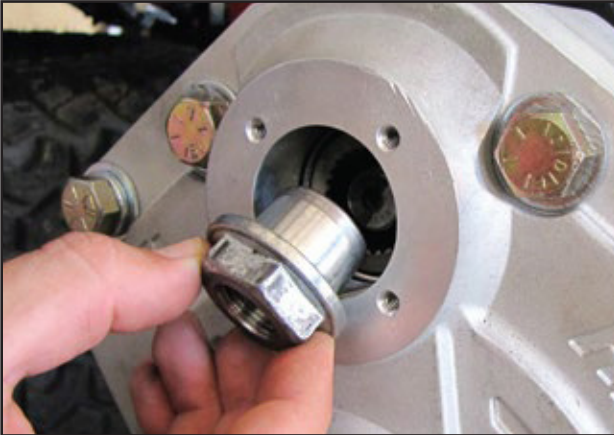

Apply LOCTITE (BLUE) to the supplied M20 shoulder axle nut (PGLC-AXNUT-5) and torque onto the drive shaft axle. (30mm) [20 ft]

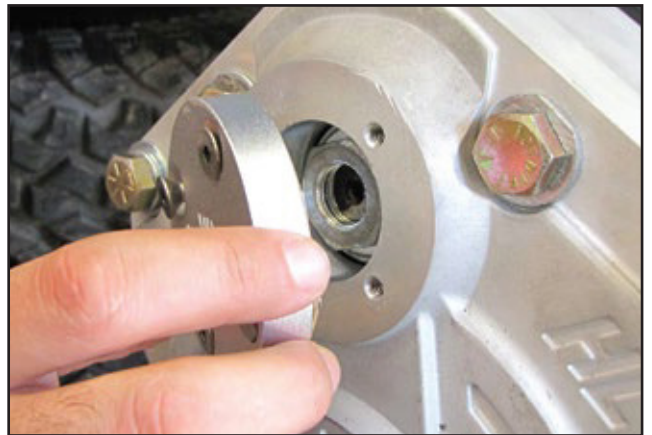

Align the portal box lid cap & gasket. Use the 1/4-20 x 3/4" screws and install the cap to the portal box. [8 ft lbs]

ROTOR ASSEMBLY

INSTALL

33

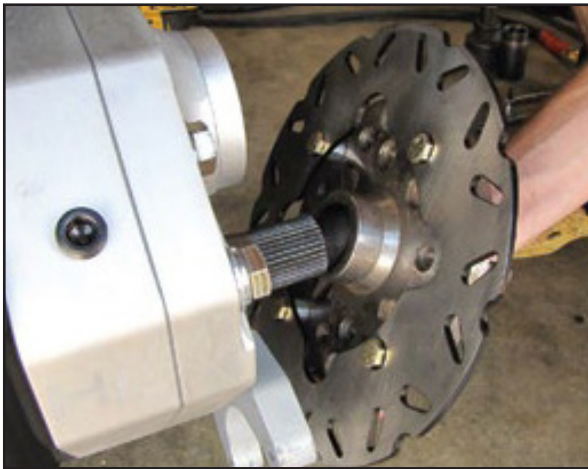

Slide on the 30mm lock washer, 30mm castle nut. (46mm) [Min 120 ft lbs]
Tighten the castle nut further if needed to align grooves with hole in the spindle for the cotter pin. Install the cotter pin, then bend it to secure it.

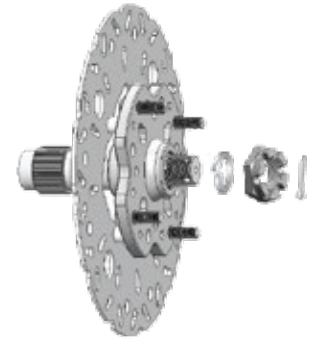

Apply waterproof grease to the spindle splines and slide the brake rotor assembly onto the spindle shaft.

REPEAT STEPS ON OPPOSITE SIDE

34

FRONT & REAR BRAKE LINE EXTENSION

Locate the proper BRAKE LINE EXTENSION. Using the supplied button head hex drive banjo bolt, connect the STOCK BRAKE LINE to the BLIND-END BRAKE LINE EXTENSION. Ensure the copper washer are on each side of the banjo fitting.

NOTE: Verify that the back of the blind hole fitting (rounded portion) is facing INWARD towards the center of the unit. .

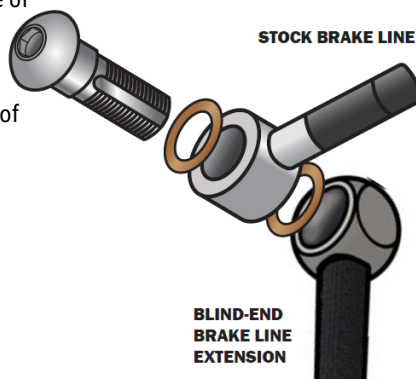

EXTENSION TO CALIPER INTALL

On the opposite end, connect the REQUIRED BRAKE LINE EXTENSION to the stock brake caliper. Verify there is a copper washer on each side of the banjo fitting. Position the fitting like the photo previewed.

BACKING PLATE

Secure the brake line to the rear of the portal backing plate by using a p-clamp. Insert a 5mm x 20mm bolt through the 5mm washer and 5mm lock nut.

NOTE: Ensure that there is no binding, pinching or interference with moving parts or sharp edges and the brake lines.

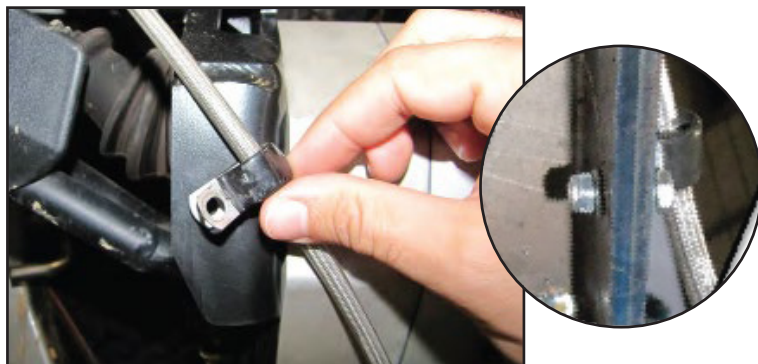

REPEAT STEPS ON OPPOSITE SIDE

35

NOTE: USE DOT 4 BRAKE FLUID

CAUTION: ALWAYS wear eye protection like safety glasses. Brake fluid will damage finished surfaces. Do not allow brake fluid to come in contact with finished surfaces.

1. Bleeding the brakes is a two person job; you will need someone at the brake caliper and someone to pump the brake foot pedal. Take precautions due to the vehicle being on jacks and/or jack stands.
2. Clean the master cylinder cover thoroughly and remove the cover.
3. With all bleeder screws open, a gravity bleed is recommended to start with. This will push all the air out at once and eliminate most of the air bubbles. (Have area prepared for spills and cleaning)
4. Add brake fluid to the indicated MAX level of the reservoir. (Any DOT 4 Brake Fluid)
5. Close off each line once you steadily see fluid coming out.
6. Begin final bleeding procedure with the caliper that is the farthest from the master cylinder. It should be this sequence - (PA) REAR, (DR) REAR, (PA) FRONT, and then (DR) FRONT.
7. You can use the supplied clear hose to attach to the caliper bleeder screw. Be sure the hose fits tightly on fitting. Now place the other end of the hose into a clean container.
8. Install a box end wrench on the caliper bleeder screw. Have your brake buddy slowly pump the foot pedal until pressure builds and holds. Have your buddy hold brake pedal down to maintain pedal pressure. Now slowly open the caliper bleeder screw 1/4" turn so the air and fluid will displace into the container.
9. Close bleeder screw, and then have your buddy release the foot pedal.

NOTE: Do not release foot pedal before the bleeder screw is tight or air may be drawn into the master cylinder... and you have to start all over again!

10. Repeat steps until clean fluid appears in the bleeder hose & all the air has been purged... Close bleeder screw, pump brakes, hold pressure, open bleeder, close bleeder, release foot pedal, check master cylinder.
11. Check the master cylinder fluid level.
NOTE: You must maintain at least 1/2" (1.27cm) of brake fluid in the reservoir to prevent air from entering the master cylinder.
12. Tighten bleeder screw securely and remove bleeder hose. Torque the bleeder screw. [4 ft lbs]
13. REPEAT procedure steps for the other three (3) brake calipers in the sequence listed above.
14. Add brake fluid to MAX level inside master cylinder reservoir after the last caliper is completed. Install master cylinder reservoir cover. Check brake system for leaks.
15. Once completed, dispose of used fluid properly.

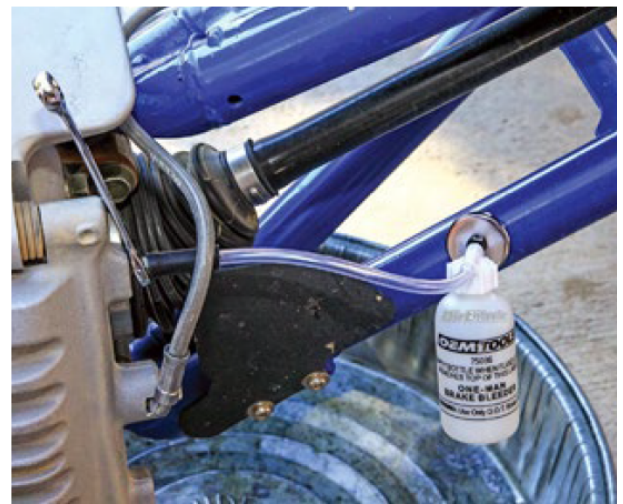
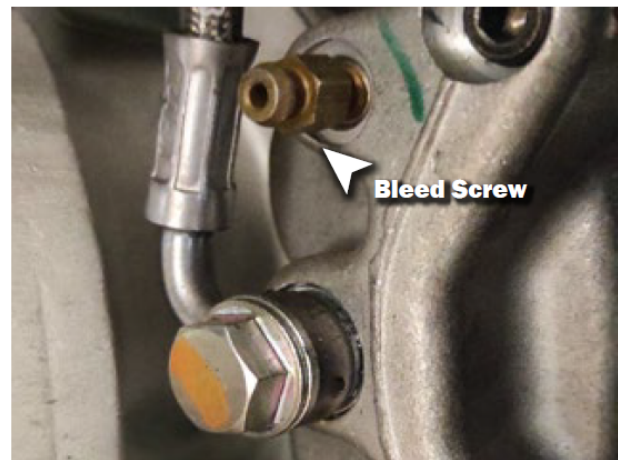

REPEAT STEPS ON OPPOSITE SIDE

36



DO NOT USE AN IMPACT TOOL ON ANY PLUGS.



ALL PLUGS MUST BE LUBRICATED OR WRAPPED IN TEFLON TAPE. PLUGS MAY NOT SIT FLUSH. DO NOT TIGHTEN TO MORE THAN 10FT LBS OF TORQUE.

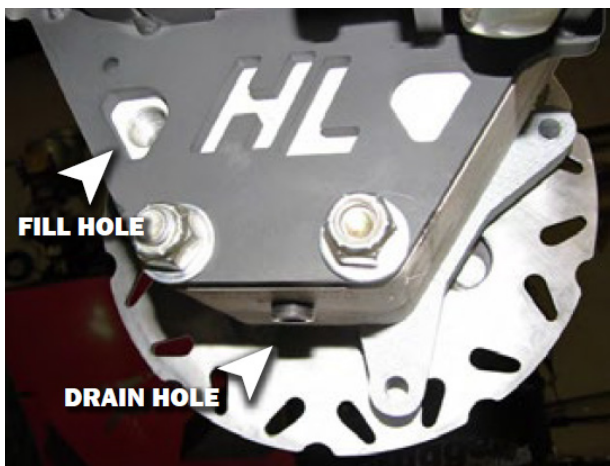

Use SAE 80W-90 oil. This gear lubricant is designed for gears operating under severe temperature and load conditions. SAE 80W-90 viscosity grade offers extended performance.

1. Ensure the vehicle is positioned securely and 'Level'.
 2. On the bottom of the box is the drain hole and plug. Make sure the plug is wrapped in Teflon tape or lubricated with oil or grease. Tighten to [10 ft lbs] (8mm)
 3. On the lower backside of the backing plate is an opening for the portal box fill hole and plug. Remove the fill plug. (8mm)
 4. Place the gear oil bottle spout into the fill hole. You can gently 'Squeeze' the bottle to help the process.
 5. Fill the portal box until the fluid starts draining back out of the fill hole. Then reinstall the fill plug, wrap the threads with Teflon tape or lubricate threads with oil or grease. [10 ft lbs] (8mm)
- CAUTION: Do not over fill past the fill plug. If the oil heats up or expands, it will cause the oil to exhaust out the axle seal.**
6. On the top of the box is the vent hole and plug. Using an Allen wrench, make sure the plug is tightened. [10 ft lbs] (8mm)

37

WHEEL INSTALL

Wheel Requirements:

- 18" or larger wheel required
- 18" wheels cannot exceed 4-1/2" backspacing
- 20" and larger wheels cannot exceed 5" backspacing

Tire Requirements:

- Up to 30" Stock
- 31" with 3" Lift Kit
- 32" to 33" Forward Kit 1.5"
- 34" Forward Kit and Lift Kit
- 35" to 37" Big Lift Kit (45%)
- 38" to 39" Big Lift Kit (45% or 60%)
- 40" to 44" Big Lift Kit (STRONGLY SUGGEST 60%)

- Install wheel lug nuts and securely tighten.
- Remove all jacks, jack stands, and other devices used to lift and hold the vehicle.
- With the suspension supporting vehicle weight, torque the wheel lug nuts using an "X"tightening pattern.

Aluminum wheels = [90 ft lbs]

Steel wheels = [50 ft lbs]

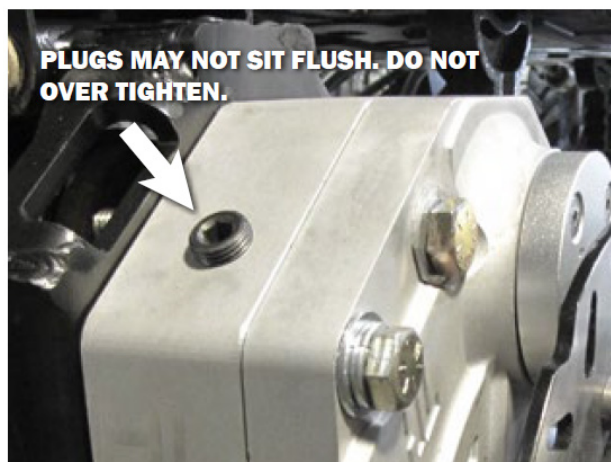

An optional vent line kit will be available in the future.

WARNING: Re-tighten lug nuts at eight (8) hours after any wheel change or anytime wheel nuts are loosened. Failure to do so could cause wheels to come off while the vehicle is in motion. This is a warning and reminder.

REMEMBER: You just bled the brakes, unbolted and bolted steering and drive train components, added more take-off torque and made many changes by adding the portal boxes. FIELD TEST this machine at LOW speed before putting into full time Play or Work Mode. Check the brakes for proper braking action & pedal reserve.

FRONT WHEEL ALIGNMENT

38

IF YOU HAVE ADJUSTABLE CONTROL ARMS, YOU MUST ADJUST THE CAMBER FIRST BEFORE PROCEEDING. DO NOT INSTALL WHEELS ONTO UTV UNTIL PROPER ALIGNMENT HAS BEEN ACHIEVED.

- Straighten steering wheel
- Make sure that the brake rotors are straight to sight or level.
- Using a tape measure, measure from inside to inside on the front and back ends of the rotors.

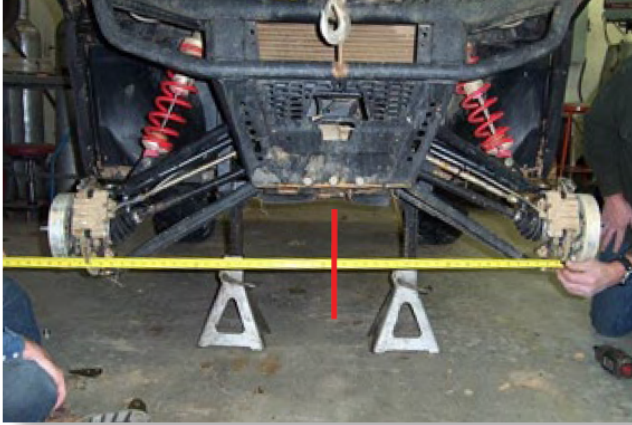

INCORRECT TOE

If the toe alignment is incorrect, measure the distance between vehicle center and the back of the rotors. This will indicate which tie rod needs adjustment.

ADJUSTING TOE

Adjust tie rods until **BOTH** measurements are the **SAME**, then adjust toe tolerance.

The recommended vehicle toe tolerance is 1/8" to 1/4" (3.175-6.35mm) toe out. This means the **FRONT MEASUREMENT IS WIDER THAN THE REAR MEASUREMENT.**

TOE ADJUSTMENT CHART

TOE (Inches)	1/16	1/8	3/16	1/4	5/16	3/8
TOE (Degrees)	0.12°	0.25°	0.38°	0.51°	0.64°	0.76°

Recommended Settings



If the **FRONT OF THE WHEELS** are facing **OUT**, adjust the tie rods **OUT** or **INCREASE** the length of the tie rod.

Measurement at the front of the tires will be **GREATER** than the rear, if the **TOE IS OUT**.



If the **FRONT OF THE WHEELS** are facing **IN**, adjust the tie rods **IN** or **REDUCE** the length of the tie rod.

Measurement at the front of the tires will be **LESS** than the rear, if the **TOE IS IN**.



IMPORTANT NOTE: When tightening the tie rod jam nuts, the tie rod ends must be held parallel to prevent rod end damage and premature wear. Damage may not be immediately apparent if done incorrectly.

After alignment is complete, tighten & torque tie rod end jam nuts to specifications. [12-14 ft lbs]

WARRANTY INFORMATION



HIGH LIFTER LIMITED LIFETIME WARRANTY

High Lifter offers a Limited Lifetime Warranty to the original purchaser that our product shall be free from defects in material and workmanship for the life of the product if utilized in accordance with the manufacturer's instructions for installation and operation of said products.

LIMITED LIFETIME WARRANTY EXTENDS TO THE FOLLOWING PRODUCT LINES:

- Lift Kits (Signature, Standard and Big Lifts)
- Control Arms
- Trailing Arms
- Radiator Relocation Kits
- Portal Gear Lifts
- Wheel Spacers
- Tow Hooks
- Control Arm Link Kits
- Racks

Damages to vehicle or any other object during the installation, use, or removal of High Lifter products are not covered under this warranty. Normal wear items included with any of the products covered under this Limited Lifetime Warranty are excluded from coverage. These items include, but are not limited to heim joints, tie rods, bearings, bushings, seals, gaskets, zinc plating, painted and powder coated finishes. Other exclusions of coverage under this warranty include, but are not limited to: damage or product failure due to improper installation, lack of maintenance, product modification, abuse, collision or use on vehicles for which product was not designed, repairs performed by anyone other than approved High Lifter personnel or made using non-High Lifter components. This warranty is valid for the original purchaser only and is non-transferable. High Lifter reserves the right to inspect any product before determining if the claim is valid and covered under this warranty. Claims determined to be caused by reasons other than a manufacturer defect will be rejected and an estimate for repair or cost of a replacement product if a repair is not possible, will be provided.

This warranty is exclusive and is in lieu of any implied warranty of merchantability, fitness for a particular purpose or other warranty of quality, whether express or implied, except the warranty of title.

WARRANTY PROCESSING

If you suspect your product is defective, **DO NOT disassemble the product** to determine the cause without prior approval as it may void your warranty status. This is especially true with our Portal Gear Lift. To begin the claim process, please e-mail our warranty team at warranty@highlifter.com and include the following in the e-mail:

- Your full name, address and contact phone number
- The year, make and model of your vehicle
- The part number of the product
- Photos of the product installed, and vehicle product is installed on
- Proof of purchase (Required for all warranty claims and you must be the original purchaser)

Once a claim is created, you will receive a return authorization number (RMA). Write this number on the outside of the box containing your defective product and include it along with your name and contact information inside the box. Product must be returned in the original box or a box of equal strength and packaging. Product sent without an RMA number visible on the outside of the box or sent COD will be refused. Ship your product to the following address:

High Lifter Products
Attn: Returns 7455 Atkinson Dr, Shreveport, LA 71129

Once your product is received, we often have your replacement or repaired product shipped back to you within 3-business days of receiving it. Please note that **High Lifter is not responsible** for shipping charges on product returned for warranty or repair, including duties and fees required by those residing outside the United States.

THANK YOU FOR CHOOSING

PORTAL WARRANTY INFORMATION

Thank you for purchasing a High Lifter Products Portal Gear Lift. Our Portal Gear Lifts have been engineered to provide superior performance on your ATV/UTV.

LIMITED LIFETIME WARRANTY:

HIGH LIFTER PRODUCTS, warrants to the **ORIGINAL** purchaser of any Portal Gear Kit for a lifetime of protection from the date of purchase against defects in materials or workmanship, subject to the following conditions:

- a) The product must be properly installed according to all installation instructions.
- b) **HIGH LIFTER** is not liable for any incidental or consequential damages to anything other than the Portal Gear Kit covered by this warranty. **HIGH LIFTER** is not liable for any incurred expenses, labor costs to install/remove/reinstall Portal Gear Kit or any OEM or aftermarket components, loss of use of machine, damage to housings or damage to any aftermarket accessory or OEM components.
- c) If the Portal Gear Kit has been disassembled or modified by a third party, the warranty is null and void.
- d) Any Portal Gear Kit damaged in a collision with any object is excluded from this warranty. However, the Portal Gear Kit may be refurbished for a fee upon repair authorization by the owner. Costs will vary depending on the condition of each Portal Gear Kit assembly.
- e) Warranty is non-transferable from the **ORIGINAL** purchaser.
- f) **HIGH LIFTER** reserves the right to inspect the Portal Gear Kit for determining if there were any defects in the installation and to determine the validity of any warranty claim. The warranty process may require the **ORIGINAL** purchaser to provide photographs of the ATV/UTV and its installed Portal Gear Kit.
- g) Items that will not be covered under the warranty are but not limited to: Bearings, Seals, Gaskets, and Wheel Studs. All other components in kit are subject to review by **HIGH LIFTER** to determine reason for failure and if they meet requirements for warranty coverage.
- h) Warranty will be void on products that show; misapplication, improper installation, abuse, lack of proper maintenance, negligence, or alteration from original design.
- i) Any parts used to repair a portal kit must be purchased from **HIGH LIFTER** or warranty will be voided. For safety reasons it is important that the proper fastener grade, thread engagement, and torque specification be followed to prevent parts from failing. See instructions for torque data/specifications.

REFUSED SHIPMENTS/ORDER CANCELLATION:

Refused shipments are subject to a 20% restocking fee plus all associated freight costs. It is our goal to ship all orders in a timely manner. If a customer wishes to cancel an order (provided it is not a special-order product), it is the responsibility of the customer to cancel the order prior to the product being shipped. If a customer cancels an order after product has been shipped, they refused shipment, cancellation, or return will be subject to a 20% restocking fee and any freight charges incurred. For orders outside the United States, any fees associated with customs or duties are non-refundable.

DAMAGED SHIPMENTS:

All claims for damaged shipments must be made within 72 hours of delivery to the point of destination. Any damage to package should be noted with carrier at the time of delivery if possible. We will not be responsible for damage claims made over 72 hours after delivery to the point of destination.

OBTAINING A WARRANTY CLAIM:

All returns for warranty must be pre-approved by calling 1.800.699.0947. After warranty approval has been granted and a Return Merchandise Approval (RMA) number issued, the Portal Gear Kit must be received by **HIGH LIFTER PRODUCTS** within 15 calendar days. The RMA number must be clearly displayed on the return box or the return will be refused. An RMA number does not imply that a replacement or refund will be issued on any product, but only that we will inspect the Portal Gear Kit for warranty claims. For orders outside the United States, any freight or fees associated with customs and duties are the responsibility of the purchaser and are non-refundable. All claims must be accompanied by the sales receipt detailing date and place of purchase, a written explanation of the problem, a phone number, and e-mail address. A copy of this receipt must be included with the Portal Gear Kit submitted for warranty repair or replacement. The purchaser is responsible for any freight charges on all warranty claims, including incoming freight to High Lifter and return freight to the purchaser.



RMA Number # _____

HIGH LIFTER PRODUCTS WARRANTY CLAIM

Name: _____

Product Number: _____

Address: _____

Place of Purchase: _____

Date of Purchase: _____

Phone Number: _____

Reason for Return: _____

E-Mail Address: _____

Reminder – This claim must be accompanied by a copy of the original receipt.

PRODUCT DISCLAIMER

THE PRODUCT IS/WILL:

- Designed and intended for use on a UTV at slow speeds.
- Increase the center of gravity.
- Increase the turning radius.
- Increase the stopping distance when adding larger tires.
- Increase and accelerate wear of factory components including bushings, bearings, ball joints, and tie rod ends.
- We cannot guarantee fitment with other aftermarket accessories.

Safety Guidelines:

- Inspect all moving factory suspension components particularly ball joints, tie rod ends, control arm connections, and brakes prior to each ride and replace if worn.
- Inspect clearances with control arms and brake lines prior to each ride.
- Wheel spacers should not be used with a Portal Gear Kit.
- 14" or larger wheels must be used with the Portal Gear Kit. 12" wheels cannot be used.
- Jumping, high speeds, and quick maneuvering should be avoided.

Maintenance Information:

- Check gear oil in portal boxes following 25 hours of riding or sooner, depending on how you ride.
- Use 4 oz of SAE 80W-90 Gear Lubricant as needed in each portal box.
- Replace worn factory components including bushings, bearings, ball joints, brakes, and tie rod ends when they show wear.

Any vehicle equipped with a Portal Gear Kit must have the enclosed large format "Warning to Driver" decal installed on the inside of the windshield or on the vehicle's dash, within driver's view. The "Warning to Driver" decal is to act as a constant safety reminder for whoever may be operating the vehicle.

INSTALLING dealer:

It is your responsibility to install the "Warning to Driver" decal and forward these installation instructions to the vehicle owner for review of warnings, product use, and maintenance information. Replacement Warning Decals are available FREE on request. These instructions are to be kept with the vehicle registration papers and owner's manual for the service life of the vehicle.

REFUSED Shipments/Order CANCELLATION:

Refused shipments are subject to a 20% restocking fee plus all associated freight costs. It is our goal to ship all orders in a timely manner. If a customer wishes to cancel an order (provided it is not a special order product), it is the responsibility of the customer to cancel the order prior to the product being shipped. If a customer cancels an order after product has been shipped, refused shipment, cancellation, or return will be subject to a 20% restocking fee and any freight charges incurred. For orders outside the United States, any fees associated with customs or duties are non-refundable.

DAMAGED Shipments:

All claims for damaged shipments must be made within 72 hours of delivery to the point of destination. Any damage to package should be noted with carrier at the time of delivery if possible. We will not be responsible for damage claims made over 72 hours after delivery to the point of destination.